

GRI

ATTREZZATURE per
ROTTAME, RIFIUTI,
EDILIZIA, DEMOLIZIONI
EQUIPMENT for
SCRAPS, WASTE MATERIALS,
BUILDING, DEMOLITIONS

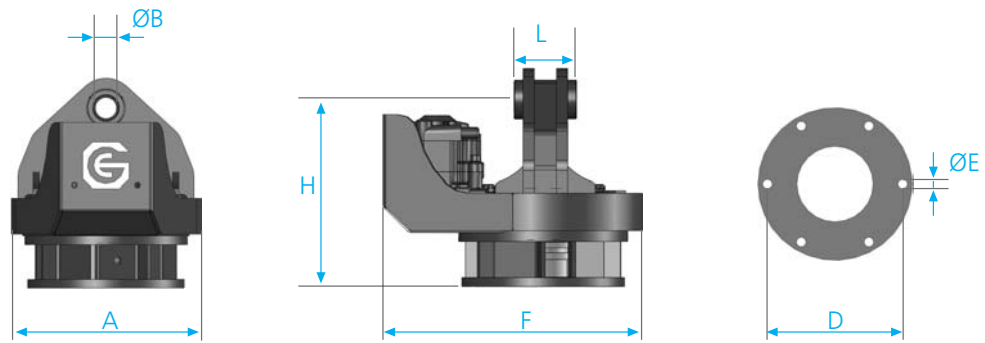



Modello Model	Coppia a 100 Bar Torque at 100 Bar	Peso Weight	Portata max Max axial load	Pressione rotazione Rotation pressure	Pressione attrezzatura Equipment pressure	Dimensioni Dimensions						
	Nm	Kg.	Ton.	Bar	Max Bar	A	C	Ø B	F	Ø D	Ø E	H
GRI 10	3600	270	10	100	320	442	140	50	580	320	22	420
GRI 15	4500	420	15	100	320	620	180	60	700	360	24	530

Modello Model	Portata Axial load	Coppia Torque	Peso Weight	Portata olio rotaz. Rec oilflow rotation	Pressione rotazione Rotation pressure	Pressione attrezzatura Equipment pressure	Dimensioni Dimensions				
	Max Ton.	Nm	Kg.	Lt./min	Max Bar	Max Bar	A	B	C	D	H
GV6-59	6	1400 (200Bar)	36	25	200	250	F 80	35	59	30	301
GV6-68	6	1400 (200Bar)	37	25	200	250	F 80	35	68	30	301
GV6-69	6	1400 (200Bar)	37	25	200	250	F 80	35	69	30	301
GV6RF	6	1400 (200Bar)	44	25	200	250	F 80	35	173/6	17	300
GV12-1	10	2200 (250Bar)	56	25	250	250	F 80	35	173/6	17	316
GV12S	10	2200 (250Bar)	58	25	250	250	F 100	45	173/6	17	332
GV17S	16	3300 (250Bar)	65	35	250	250	F 100	45	173/6	17	353
GV17S-203	16	3300 (250Bar)	67	35	250	250	F 100	45	203/6	21	352
GV17-US	16	3300 (250Bar)	70	35	250	250	F 136	52	173/6	17	383
GV17-US203	16	3300 (250Bar)	73	35	250	250	F 136	52	203/6	21	390

Modello Model	Coppia a 250 Bar Torque at 250 Bar	Peso Weight	Portata max statica Max axial load static	Portata max dinamica Max axial load static	Pressione Rotazione Rotation pressure	Pressione attrezzatura Equipment pressure	Dimensioni Dimensions					
	Nm	Kg.	Ton.	Ton.	Bar	Max Bar	Ø A	Ø B	Ø C	X	D	L
IR 10H M16	2200	84	25	7	170	320	210	180	140	6	M16	40
IR 10H M20	2200	87	25	7	170	320	235	200	160	6	M20	40
IR 20H M20	4100	145	45	15	220	320	255	220	170	9	M20	45
IR 20H M24	4100	150	45	15	220	320	280	230	170	9	M24	45

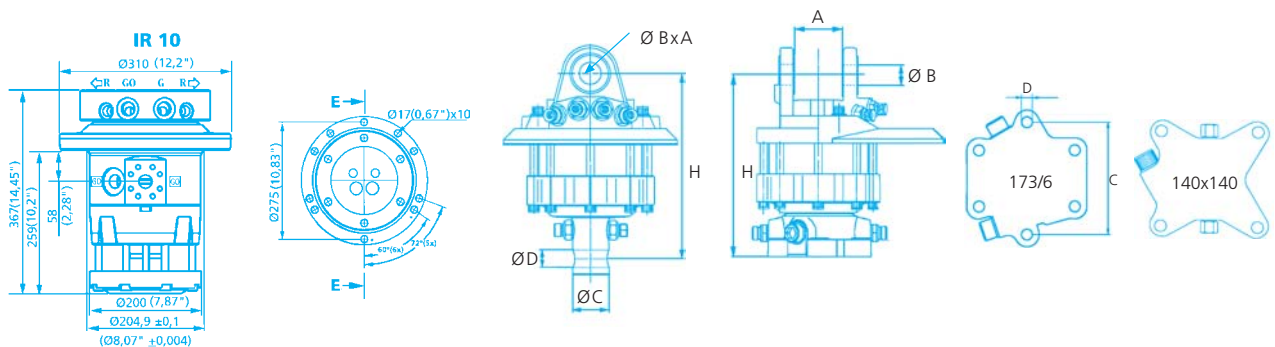

Modello Model	Portata Axial load	Coppia a 200 Bar Torque at 200 Bar	Peso Weight	Portata olio rotaz. Rec oilflow rotation	Pressione rotazione Rotation pressure	Pressione attrezzatura Equipment pressure	Dimensioni Dimensions				
	Max Ton.	Nm	Kg.	Lt./min	Max Bar	Max Bar	A	B	C	D	H
GR60	6	1500	36	20	200	250	F80.5	35	68	30	305
GR60 DB	6	1500	36	20	200	250	F80.5	35	68	30	305
GR603	6	1500	43	20	200	250	F80.5	35	173/6	17	297
GR603 DB	6	1500	43	20	200	250	F80.5	35	173/6	17	297
GR10 S	10	3000	71	40	250	300	F100.5	45	173/6	17	375